

Eagan Manufacturing Co., Inc.
P.O Box 620
Black Rock, AR 72415
870/878-6805 Fax 870/878-6280
www.eaganmfg.com

Form AI24HDR3

INSTALLATION & MAINTENANCE INSTRUCTIONS

AI24HD

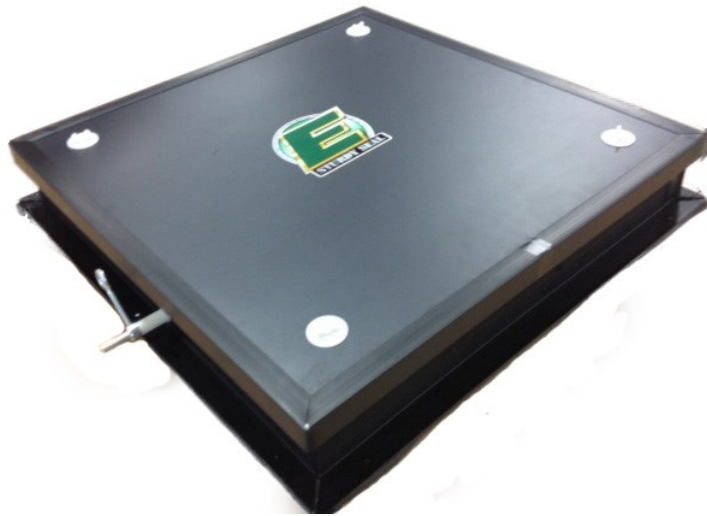

Model AI24– HD Actuated Attic Inlets



Framing Opening:

Start framing the opening with a square hole of 23" x 23". The framed hole width should be at least 1 1/2" to allow room for the flange and screws. .

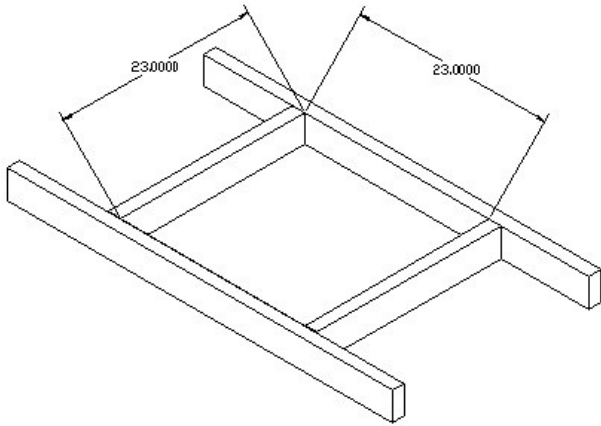

Unfold the stack and insert it in the framed hole and nail with simplex nails or roofing tacks every 12". The stack will keep the insu-

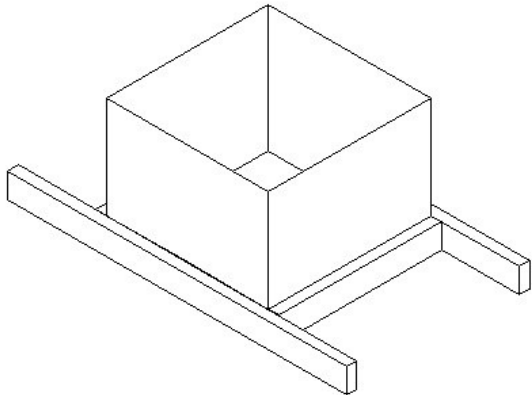

lation from falling into the attic inlet. With the stack in the hole you can now mount the Attic inlet. .

Mounting Instructions:

Actuated Control

There are two ways to use the AI24 attic inlet. It can be used as machine operated or counterweight operated. The unit is factory set to be machine operated and nothing has to be done to the unit but to mount it to the hole.. Skip to cabling for machine control section if machine control is desired.

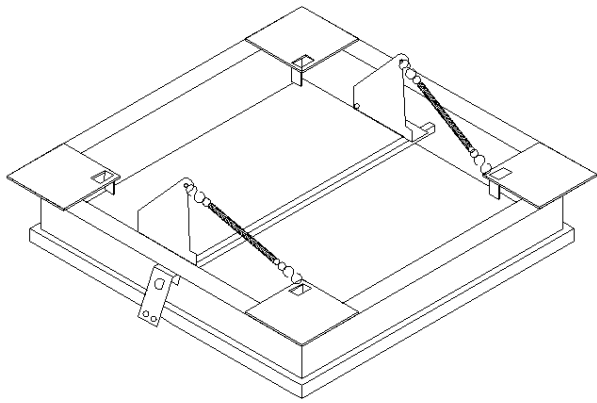

Counterweight Control:

To use the AI24 as a counterweight attic inlet the first thing that must be done is to remove the springs. To keep the doors closed when not in use the counterweight must be added to the shaft.

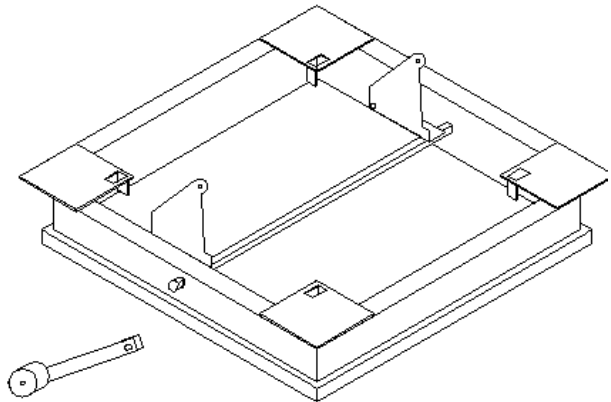

The counterweight sets the static pressure so the doors will open. The initial setting is hole 2 for the counterweight. This works very well in sloped ceiling houses. If the houses are flat roofed start the weight in the hole 1. The pres-

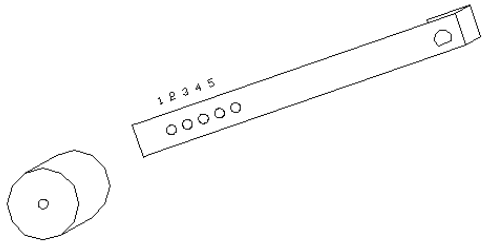

sure can be lowered by placing the counterweight up the arm. Once the counterweight is mounted and set the unit is ready to be installed. The mounting of the attic inlet is very important. The counterweight must always be facing the peak of the ceiling.

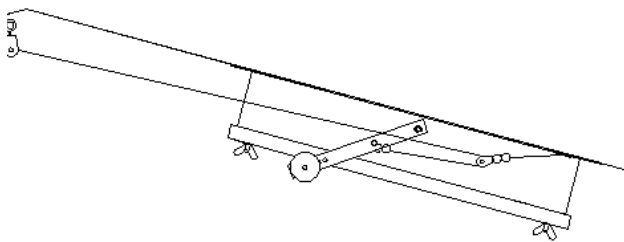

The attic inlet will now stay closed by the counterweight. The weight should keep the door closed until a static pressure acts upon the door and causes it to open. To keep the door closed when not in use, an actuator, winch or a line to tie off the doors can be used.

Cabling:

Drive Cable

If a machine or actuator is being used to control the doors or even just close a counterweight attic inlet a cable or rod needs to be installed down the entire length of the house.

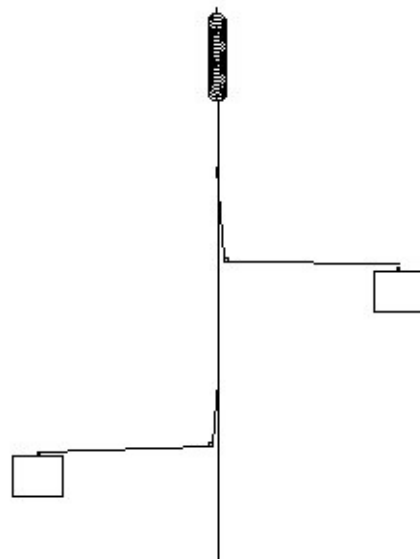

The drive cable that will open the attic inlets should be a low stretch material such as 3/16" high tensile rod. The cable or rod will tend to sag causing the doors not to open the same amount. The best way to keep this from being a problem is to use a cable support every 10 ft. and to add a spring at the end of the drive cable

Cabling For Machine Control

Machine control attic inlets are designed to stay closed when not in use. They have to be pulled open to operate. The machine sets the opening by pulling the cable causing the door to open.

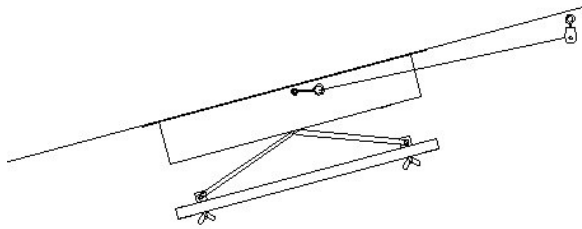

Once the drive cable is installed and tightened, the cord needs to be attached from the attic inlet to the drive cable.

First have the actuator completely close. This is the default full open position. Now tie the cord from the drive cable to the attic inlet. Pull the attic inlet to the full open position and tie off the cord. Repeat until all of the attic inlets are tied to the drive cable.

Next the closed position of the attic inlets need to be set on the actuator. This is the open position on the machine or actuator. As the machine opens and the attic inlets close stop the actuator just at the doors close completely. Allow just a little slack in the cord connecting the drive cable to the attic inlet. This ensures that the doors are closed tight and not leaking. Set the limit on the machines at this point. The machine operated attic inlets are ready to be used.

NOTE: As with any vents there will be some adjustment the first few months of operation due to cord stretch.

CABLING FOR COUNTERWEIGHT

When a counterweight is used the drive cable is only used to close the attic inlet when no longer in use. Because of this the winching has to be set so that pulling the cord closes the door. One of the springs removed from the door should be saved and used inline with the attic inlet.

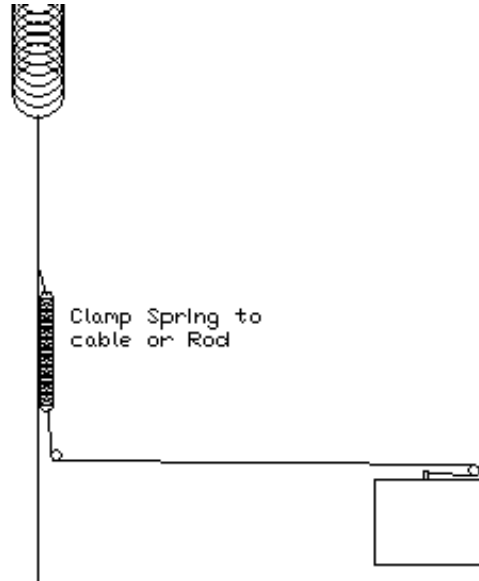

.Adding one of the springs inline with the cable keeps the drive from pulling the attic inlet too hard and damaging the unit. The curtain pulley needs to be placed behind the attic inlet as illustrated above. This allows for the door to be closed when the drive cable is pulled.

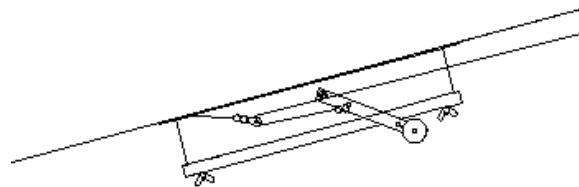

Parts Description

Item#	Qty	Description
1	1	Counterweight Arm
2	2	Axle Rod
3	1	Counterweight
4	4	Corner Plate
5	1	Inlet Frame
6	1	Axle Shaft
7	2	Scissor Arm Assembly
8	2	3/4 x 1 1/2 Swivel Link
9	2	3/4 x 3/4 Swivel Angle
10	2	Axel Connector RH & LH
11	2	3/4 x 1 3/4 Rigid Angle
12	4	Door Hangers
13	1	Machine Arm
14	1	Spring Bracket
15	1	Inlet Bottom
16	4	Nylon Wing Nut
17	4	Nylon Washer
18	2	3/4 x 2 1/4 Link
19	1	Spring